

ASSEMBLY INSTRUCTIONS

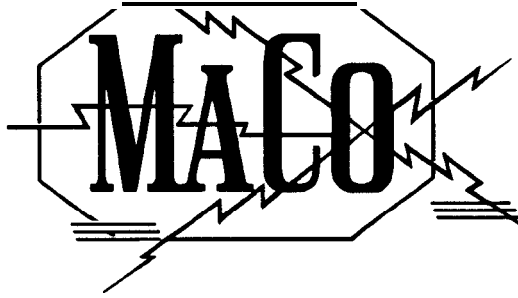

8 ELEMENT - 11 METER MAXIMUM BEAM

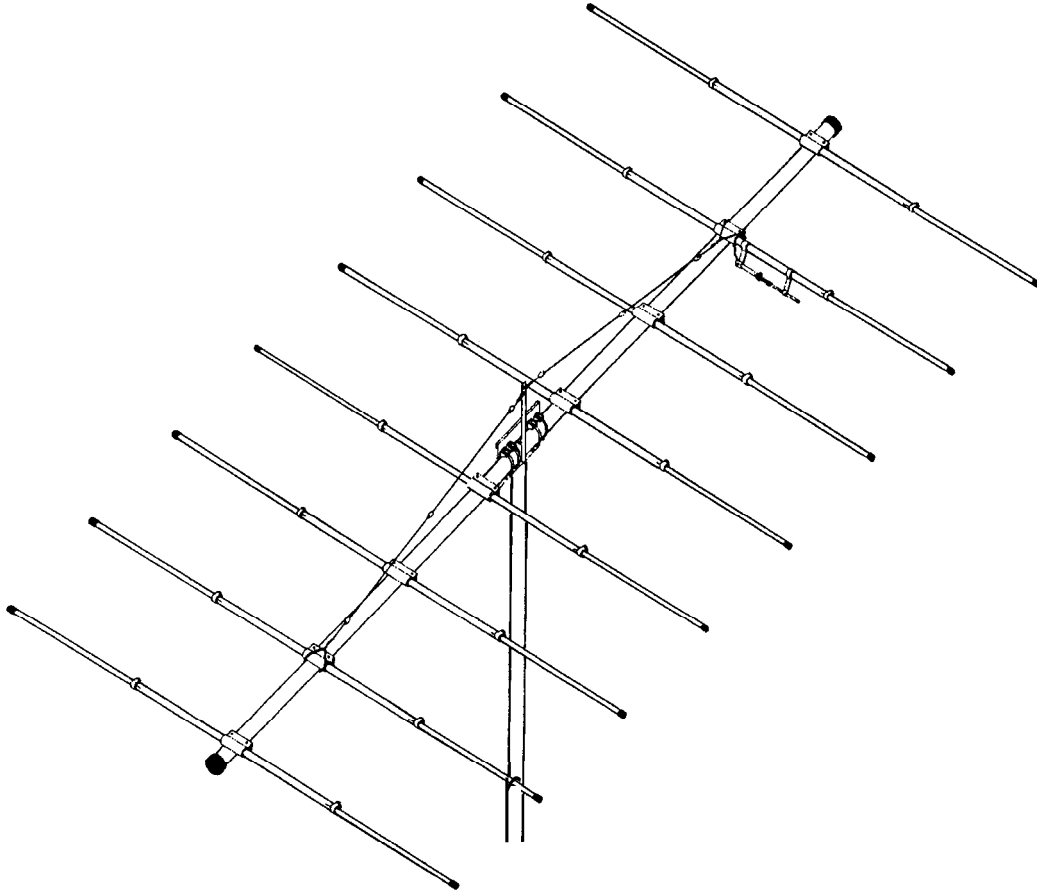

M108C

*Maco Manufacturing Co. - Division of Majestic Communications, Inc.
4091 Viscount - Memphis, Tennessee 38118 (901) 794-9494*

MACO M108C

PARTS LIST

<u>PART</u>	<u>QTYD</u>	<u>SIZE</u>	<u>N</u>	<u>G</u>	<u>T</u>	<u>H</u>	<u>DESCRIPTION</u>	<u>CHECKLIST</u>
G01P	1						GAMMA MATCH	_____
PO4	1		6"	x1/4"	18"		PLATE	_____
T01R	14	1/2"			72"		ALUM. TUBING	_____
T04P	2	1/2"	.035"		80-1/2"		ALUM. TUBING	_____
T11P	8	5/8"	.047"		72"		ALUM. TUBING SLOTTED BOTH ENDS	_____
T35P	1	2.832"	.125"		48"		ALUM. TUBING	_____
T39R	2	3"	.065"		20"		ALUM. TUBING	_____
vo2		1 1/2" x			36"		GUY SUPPORT	_____
WD3	1	1 1/2"	6/18"		50"		STEEL GUY CABLE	_____
<u>HARDWARE BAG #1</u>								
co3	3	5/8"					METAL CLAMPS - A2	_____
EG1	6						EGG INSULATORS	_____
NO1	10	5/16"					HEX NUTS	_____
NO2	10	5/16"					LOCKWASHERS	_____
N11	25	10-24					SQUARE NUTS	_____
N12	4	#10					LOCKWASHERS	_____
N15	1	1/2"					HEX NUT	_____
N16	1	1/2"					LOCKWASHER	_____
N17	3	1/2"					FLAT WASHERS/CUT	_____
N18	2	5/16"					EYEBOLTS- W/2 NUTS EACH	_____
N19	26	3/8"					HEX NUTS	_____
N20	26	3/8"					LOCKWASHERS	_____
PL2	16	.437"					PLASTIC CAPS - BLACK	_____
PL6	1	3"		1/2"			PLASTIC CAPS - BLACK	_____
PL6R	1	3"		3-1/2"			PLASTIC CAPS - RED	_____
s21	21	10-24					MACHINE SCREWS	_____
S28	1	1/2"		1"			HEX BOLT	_____
S42	1						FEMALE COAX CON. W/MOUNT NUTS	_____
s43	3	10-24					MACHINE SCREWS	_____
W58	16	5/8"					EXTRUDED ALUM. CLAMPS	_____
Z02	2						GAMMA STRAPS	_____
Z08	2						GAMMA STRAPS F/COAX. CONNECTOR	_____
<u>HARDWARE BAG #2</u>								
U01	5	2"					PLATED U-BOLTS	_____
uo3	13	3"					PLATED U-BOLTS	_____
<u>HARDWARE BAG #3</u>								
so1	5	2"					PLATED SADDLES	_____
so3	13	3"					PLATED SADDLES	_____
<u>HARDWARE BAG #4</u>								
BE3P	8						3" BOOM TO 5/8" ELEMENT MOUNTS	_____

WHEN ORDERING REPLACEMENT PARTS, ALWAYS GIVE PART NUMBER AND DESCRIPTION.

PLEASE NOTE: In an effort to keep the price on Maco Antennas down, we have decided not to clean up all the burrs and rough edges on the parts. We recommend that you deburr and clean up each part with files, sandpaper, etc. so that they go together easily. We are aware this needs to be done, but have elected not to do it to save you the money we would have to add to the price of the kit for this service.

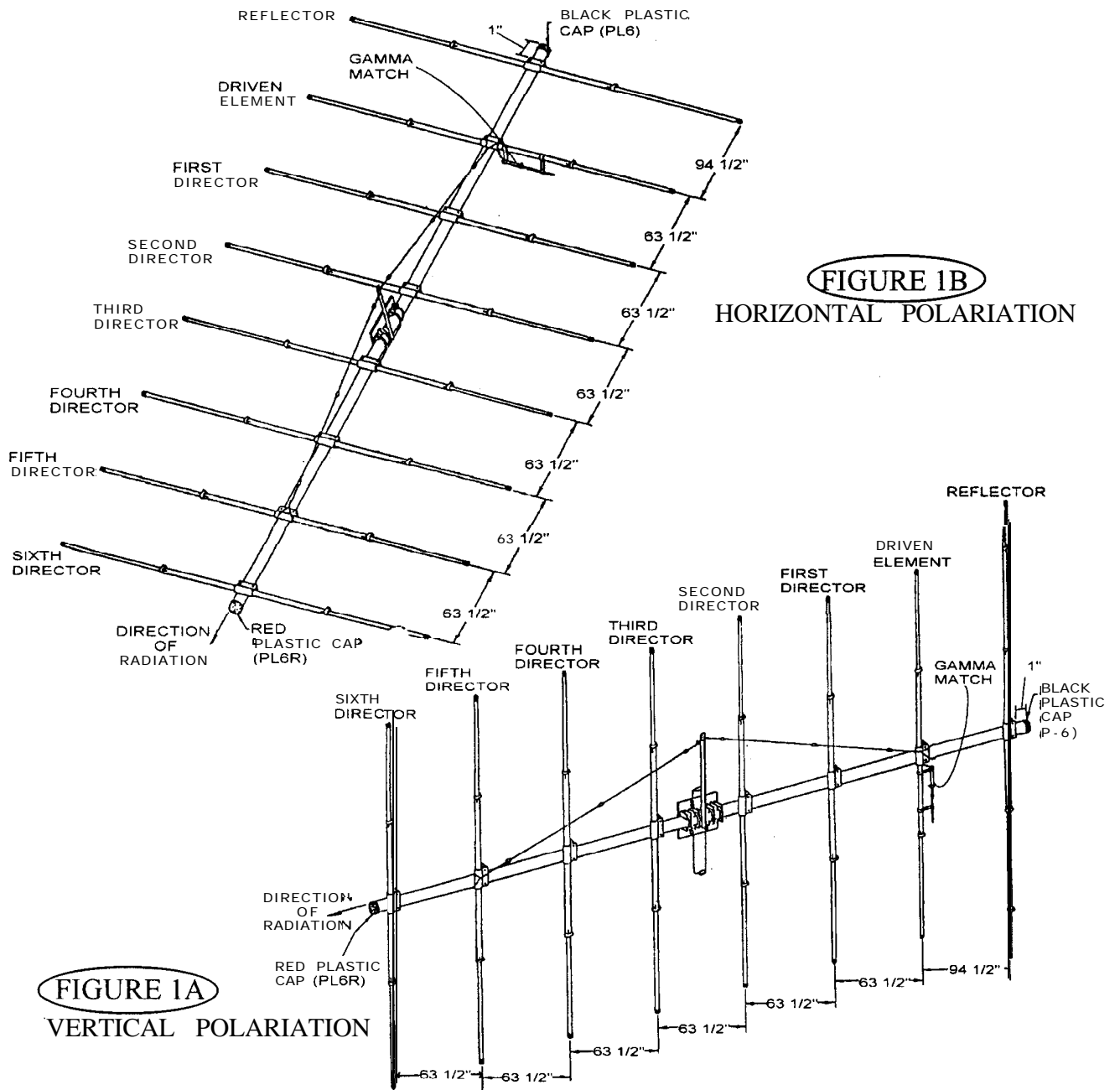

FIGURE 1A
VERTICAL POLARIZATION

FIGURE 1B
HORIZONTAL POLARIZATION

FIGURE 1 GENERAL INSTRUCTIONS

This drawing shows a view of the antenna assembled. The M108C may be used horizontally or vertically. These instructions and FIGURES 2 through 4 show the correct assembly instructions. It is highly recommended that rope be put in the elements to prolong their life. All hardware should be tightened securely, and then coated with silicon rubber sealant or similar compound to prevent loosening from wind vibration.

Take care to locate all parts accurately per dimensions given. Complete each step as instructed before going on to following steps.

Upon completion of assembly, install the red plastic cap (PL6R) on the director end of the antenna, and the black plastic cap (PL6) on the reflector end. This will allow you to determine at a glance the direction of transmit and receive.

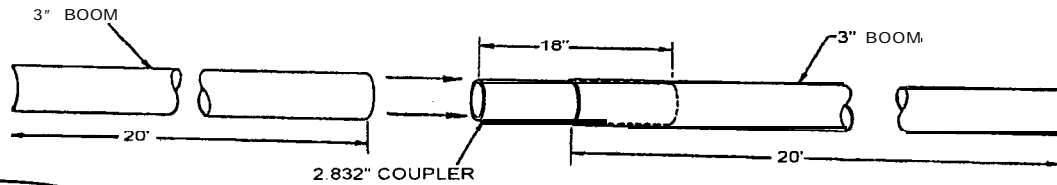

FIGURE 2A

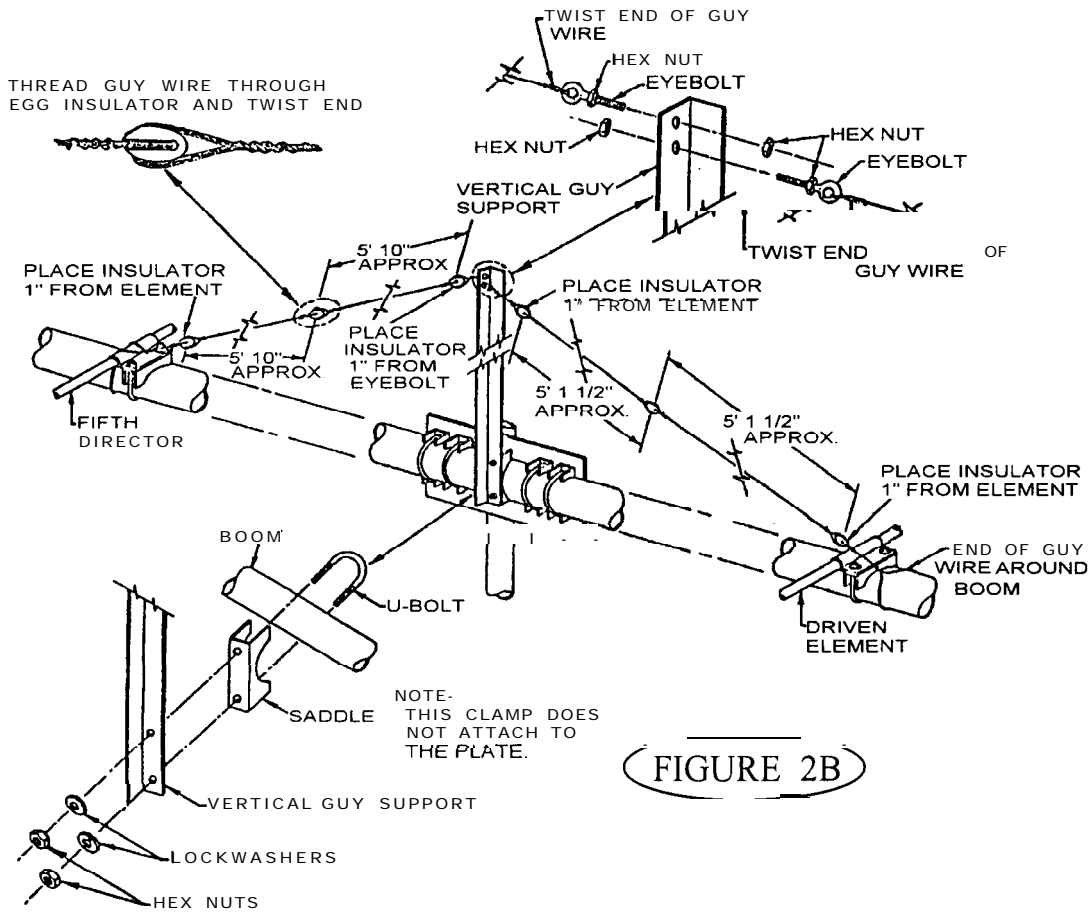

FIGURE 2B

FIGURE 2 BOOM ASSEMBLY

(See figure 2A.) First mark the center of the 2.832" O.D. boom coupler (T35P). Slide both of the 20' sections of 3" O.D. tubing over the ends of the coupler so they both butt at the coupler center.

(See figure 2B.) Mark the center of the boom to mast plate. Center the plate (P04) on the boom and secure with four of the 3" U-bolts (U03) and saddles (S03) and eight of the 5/16" lockwashers (N02) and hex nuts (N01). Avoid over-tightening the U-bolts as doing so may crush and weaken the boom. Now, reverse a 3" U-bolt so that it points away from the boom to mast plate. Slide on a 3" saddle, followed by the vertical guy support, then secure with 5/16" lockwashers and hex nuts.

From the roll of guy cable (WD3), cut two lengths 2' long. Take the two eyebolts (N18) and pass one end of the cable through the eye of the bolt and wrap. Pass the opposite end of the cable through the hole in the egg insulator (EG1) and adjust so that the length of cable between the eye of the eyebolt and the egg insulator is 1', then wrap the cable. Make two of these, then place the eyebolts onto the guy support with one nut inside and the other nut on the outside of the vertical guy support. Tighten only finger tight at this time.

Please read the **Assembly and Troubleshooting Tips** at the end of this instruction booklet before assembling elements. 1

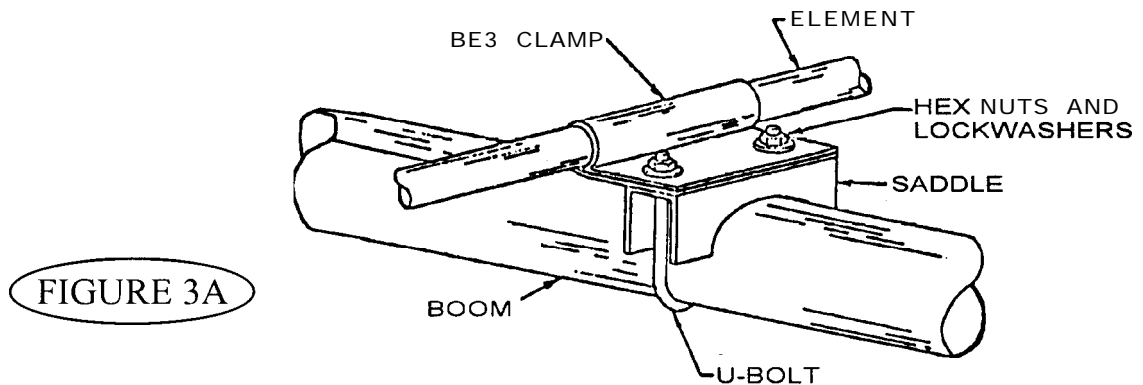

FIGURE 3A

FIGURE 3A ELEMENT CENTER SECTION MOUNTING

Refer to the main sketch (Figures 1A & B) for spacing of the elements. Slide the 5/8" x 6' center sections inside the boom to element mounts. Mount these onto the boom with 3" U-bolt assemblies as shown. Refer to Figure 4 (Gamma Match Assembly) before mounting the driven element and note the position of the coaxial connector assembly. Space the first saddle 1" from the end of the boom. Again, be careful not to over-tighten the U-bolts. Line up all the sections after mounting with a level or by any other accurate means. At this time, refer to Figure 2B and complete the boom guy support system.

Allow 6" of cable for the egg insulator wraps and 16" for the wraps around the boom at the boom to element mounts. Distances shown should be adhered to plus or minus 1". Pull the sag out of the boom by tightening the outside nuts on the guy support, then lock the inside nuts against the guy support.

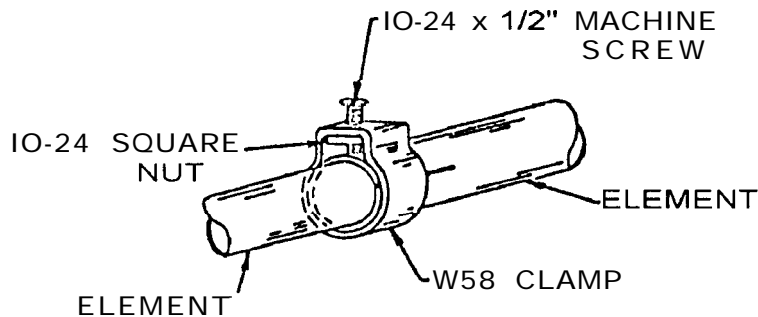

FIGURE 3B

FIGURE 3B ELEMENT END SECTION MOUNTING

Assemble the W58 clamps as shown in Figure 2B. Thread the 1/2" machine screw (S21) into the square nuts (N1) only slightly at this time. Refer to Figure 4 (Gamma Match Assembly) and note the position of the 5/8" metal clamps that will attach the gamma match to the driven position.

Insert the 1/2" O.D. x 72" tubing (no slots) into the driven element and director center sections. Slide on a W58 clamp assembly over each element and tighten slightly.

Assemble the reflector in the same manner by using the 1/2" O.D. x 72" slotted one end sections.

At this time, refer to the element length chart on page 7 and set the element lengths. In setting element lengths, telescope the 1/2" O.D. into the 5/8" O.D. by equal amounts. In any case, the minimum length telescoped into the next larger size should be 3". Measure overall element lengths, then push the .437" black plastic caps (PL2) over the ends of the premeasured elements.

MOUNTING

The M108C is designed to accept a 2" O.D. mast. A 1/4" heavy duty mast designed for this purpose is recommended. If mounted on a guyed tower, break up the guys every 3' by using egg insulators in the guy lines for the top 20' of the guy cables. Also, the guys should be located at least 12' below the level of the boom. Although it may be desirable to mount the antenna on a mast so that the elements clear the top of the tower, this should not be attempted unless you are certain that your installation is sturdy enough for this type of installation. Experimentation has shown little, if any, effect on the operation of the antenna by mounting it 2' above the top of the tower, or by mounting a rotator so that it lies between the vertical elements. The first consideration should always be the mechanical stability of the antenna.

BOOM TO MAST TILT FEATURE

The 1/2" x 3 1/2" hex bolt, 1/2" lockwasher, (3) 1/2" flat washer cut and 1/2" hex nut are provided to give a tilt feature to the boom, if desired.

A hole will have to be drilled through your mast to accommodate the 1/2" bolt.

Place the parts as shown below.

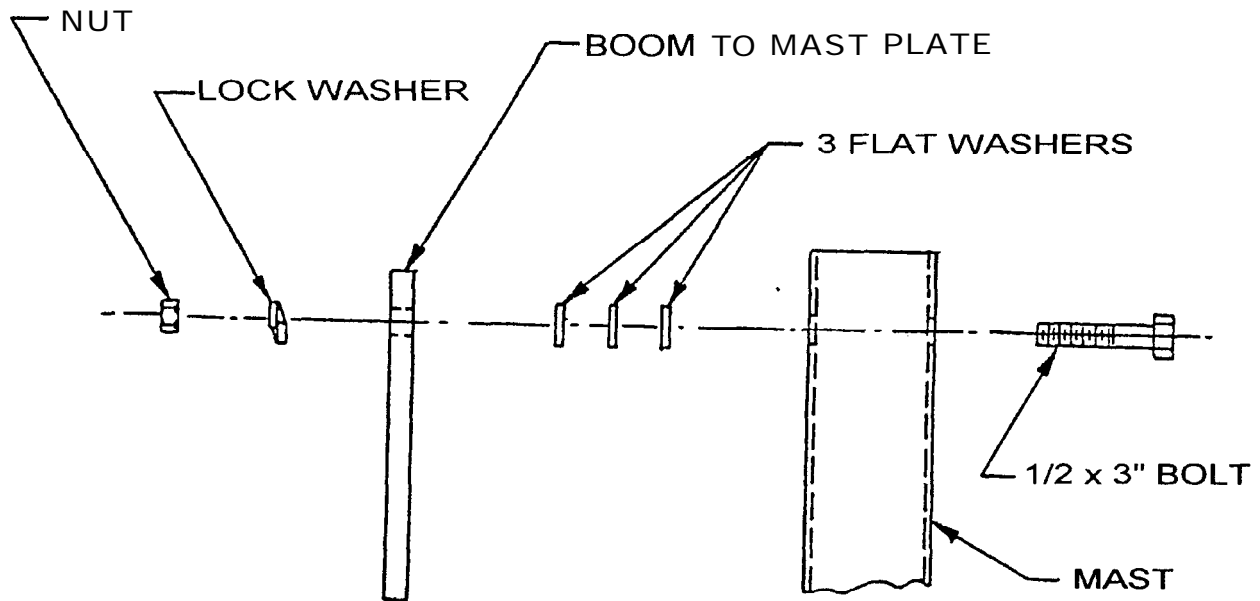

M108C DIMENSIONS

FREQUENCY	REFLECTOR	DRIVEN ELEMENT	DIRECTOR 1	DIRECTOR 2	DIRECTOR 3	DIRECTOR 4.5.6
26,500	18' 10"	1T 1 1"	17' 2"	1T 1"	16' 10"	16' 10"
26,550	18' 10"	1T 1 0"	17' 2"	1T 1"	16' 10"	16' 9"
26,600	18' 10"	1T 1 0"	17' 2"	1T 0"	16' 10"	16' 9"
26,650	18' 9"	17' 9"	17' 1"	1T 0"	16' 9"	16' 8"
26,700	18' 9"	1T 9"	17' 1"	1T 0"	16' 9"	16' 8"
26,750	18' 8"	1T 9"	17' 1"	16' 11"	16' 9"	16' 8"
26,800	18' 8"	1T 8"	1T 0"	16' 11"	16' 8"	16' 7"
26,850	18' 7"	1T 8"	1T 0"	16' 10"	16' 8"	16' 7"
26,900	18' 7"	1T T	16' 11"	16' 10"	16' 7"	16' 7"
26,950	18' 7"	1T 7"	16' 11"	16' 10"	16' 7"	16' 6"
27,000	18' 6"	1T 7"	16' 11"	16' 9"	16' 7"	16' 6"
27,050	18' 6"	1T 6"	16' 10"	16' 9"	16' 6"	16' 5"
27,100	18' 5"	17' 6"	16' 10"	16' 9"	16' 6"	16' 5"
27,150	18' 5"	1T 6"	16' 10"	16' 8"	16' 6"	16' 5"
27,200	18' 5"	1T 5"	16' 9"	16' 8"	16' 5"	16' 4"
27,250	18' 4"	17' 5"	16' 9"	16' 7"	16' 5"	16' 4"
27,300	18' 4"	17' 4"	16' 8"	16' 7"	16' 4"	16' 4"
27,350	18' 3"	17' 4"	16' 8"	16' 7"	16' 4"	16' 3"
27,400	18' 3"	17' 4"	16' 8"	16' 6"	16' 4"	16' 3"
27,450	18' 3"	1T 3"	16' 7"	16' 6"	16' 3"	16' 3"
27,500	18' 2"	1T 3"	16' 7"	16' 6"	16' 3"	16' 2"
27,550	18' 2"	17' 2"	16' 7"	16' 5"	16' 3"	16' 2"
27,600	18' 1"	17' 2"	16' 6"	16' 5"	16' 2"	16' 1"
27,650	18' 1"	17' 2"	16' 6"	16' 5"	16' 2"	16' 1"
27,700	18' 1"	1T 1"	16' 6"	16' 4"	16' 2"	16' 1"
27,750	18' 0"	1T 1"	16' 5"	16' 4"	16' 1"	16' 0"
27,800	18' 0"	1T 1"	16' 5"	16' 4"	16' 1"	16' 0"
27,850	17' 11"	1T 0"	16' 4"	16' 3"	16' 1"	16' 0"
27,900	17' 11"	1T 0"	16' 4"	16' 3"	16' 0"	15' 11"
27,950	17' 11"	1T 0"	16' 4"	16' 2"	16' 0"	15' 11"
28,000	17' 10"	16' 11"	16' 3"	16' 2"	16' 0"	15' 11"
28,050	1f 10"	16' 11"	16' 3"	16' 2"	15' 11"	15' 10"
28,100	1f 10"	16' 10"	16' 3"	16' 1"	15' 11"	15' 10"
28,150	1f 9"	16' 10"	16' 2"	16' 1"	15' 11"	15' 10"
28,200	1f 9"	16' 10"	16' 2"	16' 1"	15' 10"	15' 9"
28,250	17' 8"	16' 9"	16' 2"	16' 0"	15' 10"	15' 9"
28,300	17' 8"	16' 9"	16' 1"	16' 0"	15' 10"	15' 9"
28,350	17' 8"	16' 9"	16' 1"	16' 0"	15' 9"	15' 8"
28,400	17' 7"	16' 8"	16' 1"	15' 11"	15' 9"	15' 8"
28,450	17' 7"	16' 8"	16' 0"	15' 11"	15' 9"	15' 8"
28,500	17' 7"	16' 8"	16' 0"	15' 11"	15' 8"	15' 7"
28,550	17' 6"	16' 7"	16' 0"	15' 10"	15' 8"	15' 7"
28,600	17' 6"	16' 7"	15' 11"	15' 10"	15' 8"	15' 7"
28,650	17' 5"	16' 7"	15' 11"	15' 10"	15' 7"	15' 6"
28,700	17' 5"	16' 6"	15' 11"	15' 9"	15' 7"	15' 6"
28,750	17' 5"	16' 6"	15' 10"	15' 9"	15' 7"	15' 6"
28,800	17' 4"	16' 5"	15' 10"	15' 9"	15' 6"	15' 5"
28,850	17' 4"	16' 5"	15' 10"	15' 8"	15' 6"	15' 5"
28,900	1T 4"	16' 5"	15' 9"	15' 8"	15' 6"	15' 5"
28,950	1T 3"	16' 4"	15' 9"	15' 8"	15' 5"	15' 4"
29,000	1T 3"	16' 4"	15' 9"	15' 7"	15' 5"	15' 4"
29,050	1T 3"	16' 4"	15' 8"	15' 7"	15' 5"	15' 4"
29,100	17' 2"	16' 3"	15' 8"	15' 7"	15' 4"	15' 4"
29,150	17' 2"	16' 3"	15' 8"	15' 6"	15' 4"	15' 3"
29,200	1T 1"	16' 3"	15' 7"	15' 6"	15' 4"	15' 3"
29,250	1T 1"	16' 2"	15' 7"	15' 6"	15' 3"	15' 3"
29,300	1T 1"	16' 2"	15' 7"	15' 6"	15' 3"	15' 2"
29,350	1T 0"	16' 2"	15' 6"	15' 5"	15' 3"	15' 2"
29,400	1T 0"	16' 1"	15' 6"	15' 5"	15' 2"	15' 2"
29,450	1T 0"	16' 1"	15' 6"	15' 5"	15' 2"	15' 1"
29,500	16' 1 1	16' 1 1	15' 5"	15' 4"	15' 2"	15' 1"

* **NOTE:** THESE DIMENSIONS ARE APPROXIMATE. REFER TO THE INSTRUCTIONS ON ADJUSTING THE S.W.R. TO DETERMINE EXACT SETTINGS. THERE ARE 2 SEPARATE GAMMA ADJUSTMENTS, 1. CAPACITOR ADJUSTMENT, 2. SLIDER POSITION. **DO NOT MOVE BOTH AT THE SAME TIME.** MOVE THE CAPACITOR FIRST, THEN, IF NECESSARY MOVE THE SLIDER. AND GO BACK TO THE CAPACITOR.

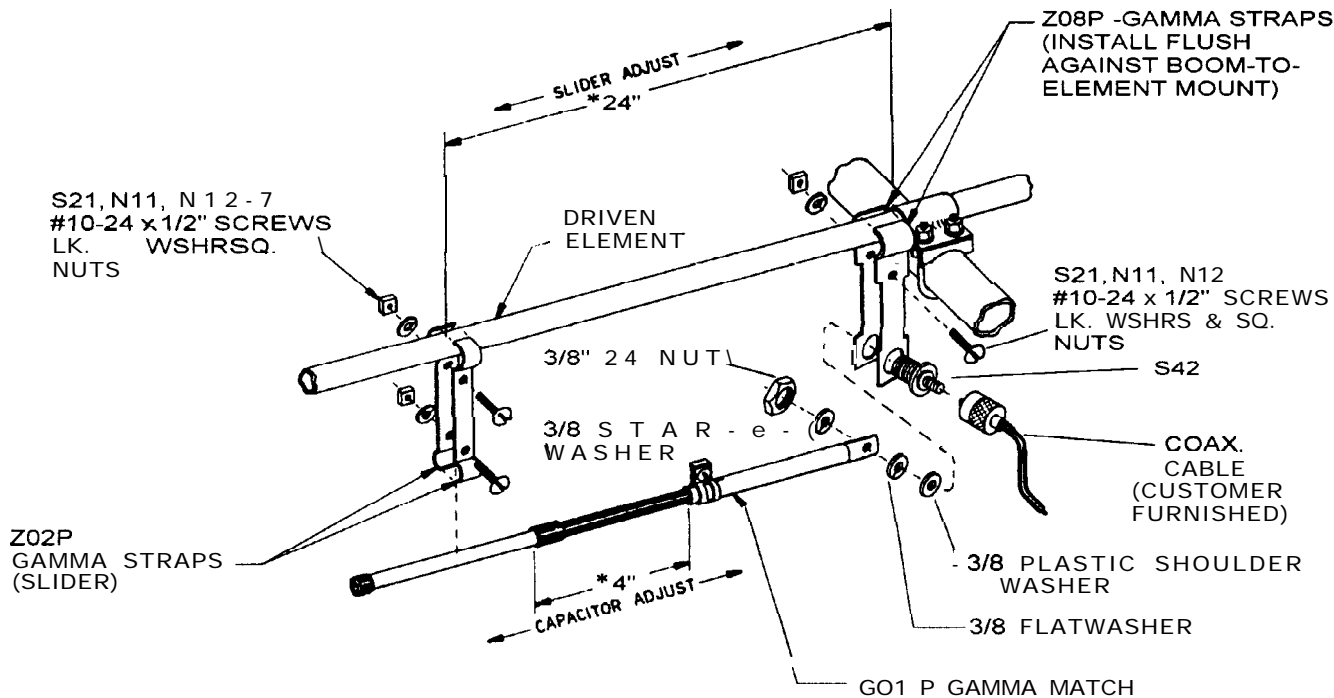

FIGURE 4 GAMMA MATCH MOUNTING

Mount the gamma match (G01P) to the driven element, using the gamma straps (202, Z08) and attaching hardware as shown. Attach your 52 ohm coaxial cable to the connector (S42) and dress along boom and down the mast. The gamma is shown pointing down - this is to let water out.

ADJUSTING THE STANDING WAVE RATIO (SWR)

Refer to Figure 4. The dimensions given are approximate and should be used as a starting point. * The gamma match has 2 adjustments. First is the capacitor adjust and second is the slider adjust. Connect a SWR bridge coax between your transmitter and the antenna and check the SWR. If adjustment is required, loosen the clamp on the gamma match and the screws holding the slider (gamma straps (202)). Next move the capacitor adjustment first one direction, then the other until a minimum SWR reading is obtained. If SWR is not yet satisfactory, move the slider out 2" away from the boom. If the reading has gone up move the slider back to the original position and then 2" towards the boom. Now readjust the capacitor for minimum SWR. You should now be able to determine which direction to move the slider. Repeat the above procedure moving the slider in smaller increments until a satisfactory SWR is obtained. Tighten all hardware. Disconnect the SWR bridge and reconnect your coaxial cable.

NOTE!

When assembling for vertical use, set antenna on a pole about 8 to 9 feet above the ground horizontally and adjust SWR to 1.7. When you turn the antenna vertical and mount it on the tower, etc., the SWR will drop to 1.4 to 1.5. This is good; QUIT! Antenna results best if vertical antenna clears the top of the tower.