

ASSEMBLY INSTRUCTIONS

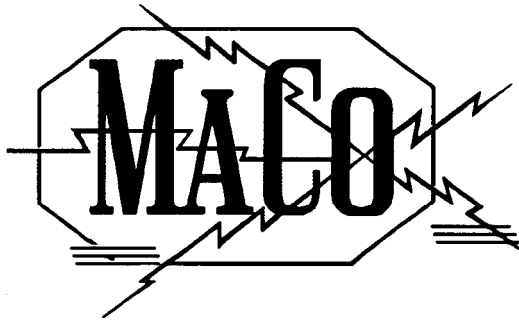

SWITCHABLE POLARITY 8 ELEMENT BEAM

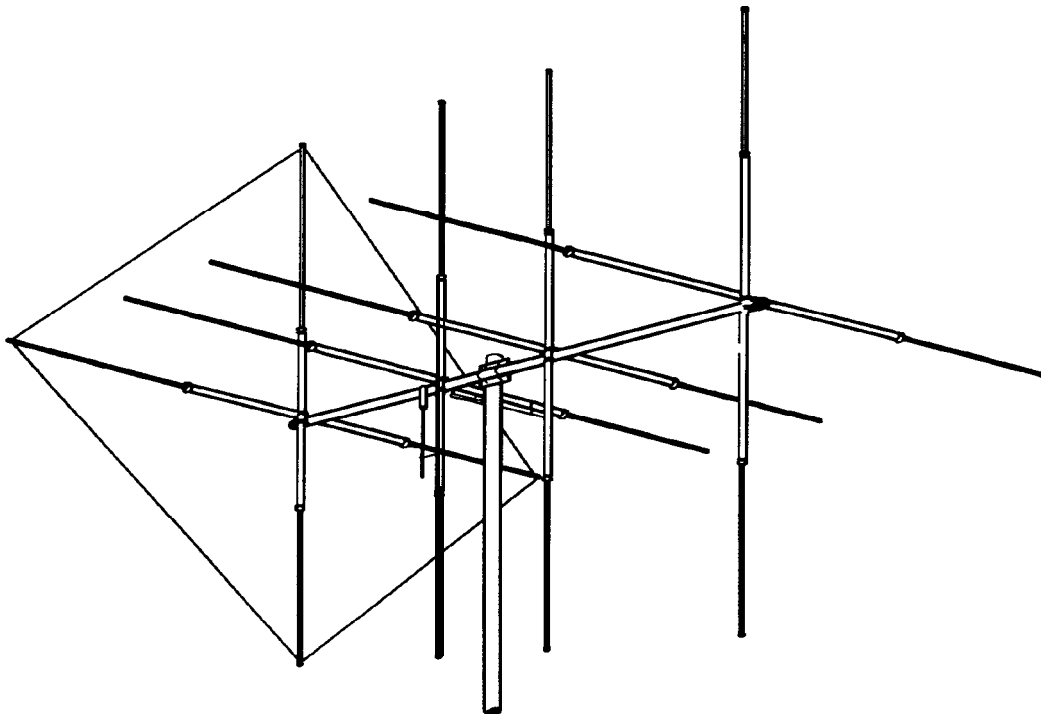

SHOOTING STAR

*Maco Manufacturing Co. - Division of Majestic Communications, Inc.
4091 Viscount - Memphis, Tennessee 38118 (901) 794-9494*

MACO SHOOTING STAR

PARTS LIST

<u>PART</u>	<u>QTY</u>	<u>O.D.</u>	<u>SIZE</u>	<u>LENGTH</u>	<u>DESCRIPTION</u>	<u>CHECKLIST</u>
T41P	1	2"	.047"	72"	Alum. Tubing swaged both ends	_____
T51P	2	2"	.047"	72"	Alum. Tubing slotted one end	_____
T11P	8	5/8"	.047"	72"	Alum. Tubing slotted both ends	_____
T01	12	1/2"	.035"	72"	Alum. Tubing	_____
P02P	1		5"x1/4"	5"	2" Boom to 2" Mast Plate	_____
G01P	2				11 Meter Gamma Matches	_____
W04P	1		14 GA.	40'	Copper Wire	_____
FA1P	4			48"	Fiberglass Rods	_____

HARDWARE BAG #1

U01	14		2"		Plated U-Bolts	_____
-----	----	--	----	--	----------------	-------

HARDWARE BAG #2

S01	14		2"		Plated Saddles	_____
-----	----	--	----	--	----------------	-------

HARDWARE BAG #3

BE2P	8		2"		Element-to-Boom Mounts	_____
------	---	--	----	--	------------------------	-------

HARDWARE BAG #4

W58P	16		5/8"		Alum. Clamps	_____
PL2P	12		.437"		Plastic Caps - Black	_____
PL5P	1		2"		Plastic Cap - Black	_____
S21	26		10-24	/2"	Machine Screws	_____
N11	28		10-24		Square Nuts	_____
PL5R	1		2"		Plastic Caps - Red	_____
N01	28		5/16"		Hex Nuts	_____
N02	28		5/16"		Lockwashers	_____
N12	12		#10		Lockwashers	_____
N26	4		#10		Flat Washers	_____
Z02P	4		1/2"	4"	Gamma Straps	_____
Z08P	4				Gamma Straps f/ Coax Connectors	_____
S42	2				Coax. Conn. w/ Mounting Nut	_____

WHEN ORDERING REPLACEMENT PARTS, ALWAYS GIVE PART NUMBER AND DESCRIPTION.

PLEASE NOTE: In an effort to keep the price on Maco Antennas down, we have decided not to cleanup all the burrs and rough edges on the parts. We recommend that you deburr and clean up each part with files, sandpaper, etc. so that they go together easily. We are aware this needs to be done, but have elected not to do it to save you the money we would have to add to the price of the kit for this service.

MACO SHOOTING STAR

ASSEMBLY INSTRUCTIONS

FIGURE 1 GENERAL INSTRUCTIONS

This drawing depicts an overall view of what the antenna should look like upon completion of assembly. Refer to Figures 2 thru 4 for specific assembly details. All hardware should be coated with a silicon rubber sealant or a similar compound to insure that wind vibration does not cause it to work loose.

FIGURE 2 BOOM ASSEMBLY

To assemble the boom, slide the slotted ends of the boom sections (T51P) onto both swaged ends of the center boom section (T41P). Secure both joints with 2" U-bolts, saddles and hardware as shown in detail 2A.

Next mark the boom center and mount the boom-to-mast plate (P02P) using 2" U-bolts, saddles and hardware as shown in detail 2B.

This antenna is designed for mounting on a 2" O.D. heavy duty mast. Mount using 2" U-bolts, saddles and hardware as shown in detail 2C.

FIGURE 3A ELEMENT ASSEMBLY

Prior to assembling elements, slide a boom-to-element mount (BE2P) onto each of the 8 element center section (T11P).

Assemble each element as shown using the clamps and hardware specified. Refer to the element table to determine dimensions for each element. Install a black plastic cap (PL2) onto both ends of each element.

Assemble the reflector elements in the same manner, sliding the fiberglass arms approximately 6 inches into the ends of the center sections (T11P). Snug the clamps, but don't tighten them at this time because the arms will have to be adjusted after installing the reflector wire.

FIGURE 3B ELEMENT MOUNTING

Mark each element at the center and be sure that the boom-to-element mounts (BE2P) are centered on the elements before tightening hardware.

Starting 1 1/2" from the director end of the boom, mount each element using 2" U-bolts, saddles, boom-to-element mounts and hardware shown. Refer to Figures 1 and 3B for element spacing instructions.

MACO MANUFACTURING, 4091 VISCOUNT AVE., MEMPHIS, TN 38118
For parts or information call (901) 794-9494.

FIGURE 3C REFLECTOR ASSEMBLY

The length of the reflector wire is very critical. REMEMBER: The Reflector dimensions are only preliminary. Change to get equal side of 9' 6". Fiberglass length is not critical, however, the equal wire length of 9' 6" is very critical. It must be the correct length to operate correctly. Take the wire (WO4P) and uncoil it making sure that there are no kinks; secure it to a nail. Pull the wire until it stretches an inch or so. The easy way to get the correct length for the reflector loop is as follows

1. Drive 2 nails in a board or fence 1/2 the length of the loop apart --which is 228" (5.790m) between them.
2. Stretch the wire around the nails by hand as tightly as possible and splice ends together. Solder the splice. Remove one nail and remove the loop. Cut any excess wire off.
3. Loosely assemble the machine screws (S21), flatwashers (N26), lockwashers (N12), and hex nuts (N06) onto the lugs of the fiberglass arms, adjusting the length as shown.
4. Tighten 3 of the 4 clamps that hold the fiberglass rods.
5. Install the wire as shown.
6. Tighten the wire by pulling the fourth fiberglass rod until the wire is the same tightness as it was around the nails. The wire loop is now the correct length. Note the total length of the loop is critical, and also is the length of each side.

FIGURE 4 GAMMA MATCH MOUNTING

Mount the (2) gamma matches (G01P) to the horizontal and vertical driven elements, using the gamma straps (Z02P, Z08P) and attaching hardware as shown. Attach your 52 ohm coaxial cables to the connectors (S42) and dress along boom and down the mast.

ADJUSTING STANDING WAVE RATIO

Refer to Figure 4. The dimensions given are approximate and should be used as a starting point. The following instructions cover the adjustment of one gamma match. To adjust the second gamma match, simply repeat this procedure.

The gamma match has 2 adjustments. First is the capacitor adjust and the second is the slider adjust. Connect a S.W.R bridge to the coax between your transmitter and the antenna and check the S.W.R. If adjustment is required loosen the clamp on the gamma match and the screws holding the slider (Gamma Straps Z02P). Next move the capacitor adjustment first in one direction then the other until a minimum S.W.R. reading is obtained. If S.W.R. is not yet satisfactory, move the slider out 2" away from the boom. If the reading has gone up, move the slider back to the original position and then 2" toward the boom. Now readjust the capacitor for minimum S.W.R. you should now be able to determine which direction to move the slider. Repeat the above procedure moving the slider in smaller increments until a satisfactory S.W.R. reading is obtained. Tighten all hardware. Disconnect the S. W. R. bridge and reconnect your coaxial cable.

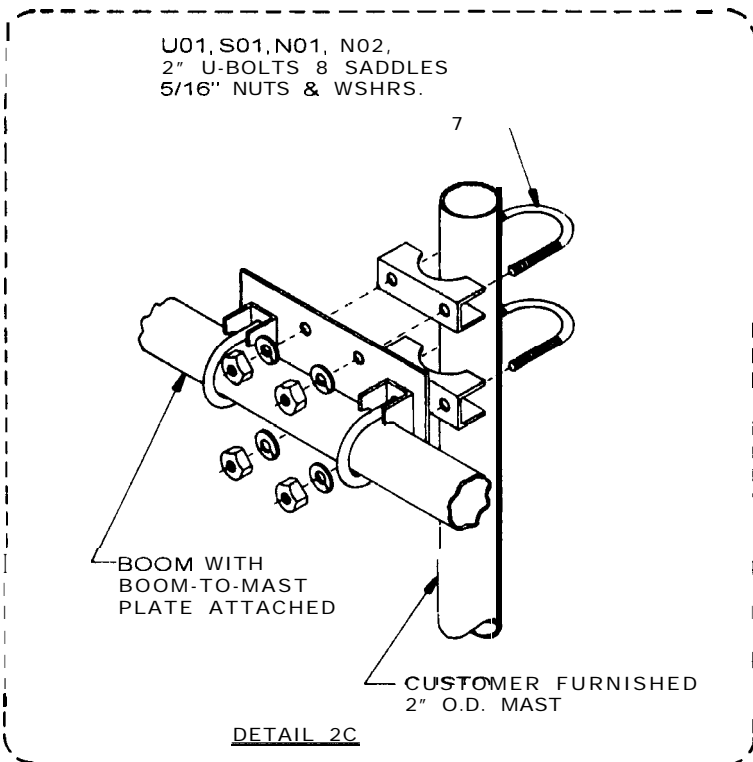
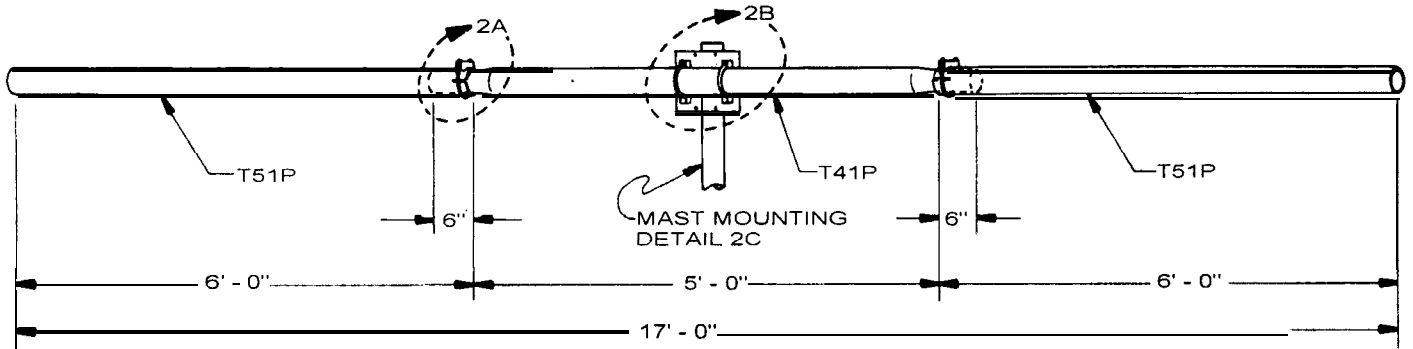
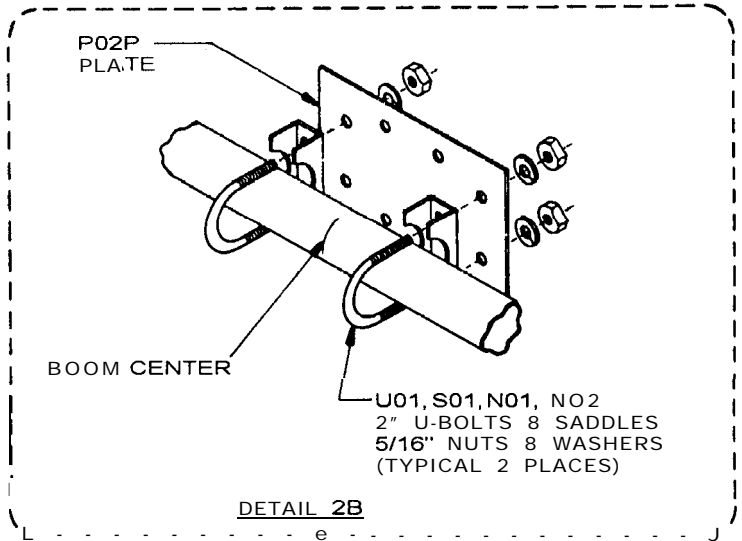
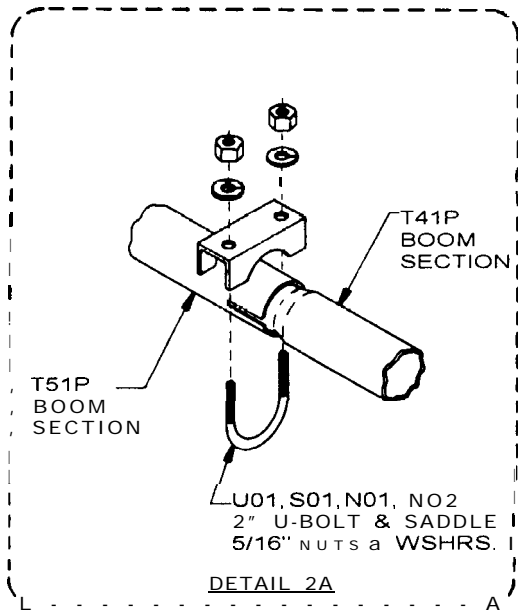

SHOOTING STAR BOOM ASSEMBLY

FIGURE 2

ELEMENT	DIMENSION	
	A	B
DRIVEN	17' 5"	5' 8 1/2"
1ST DIRECTOR	17'	5' 6"
2ND DIRECTOR	16' 6"	5' 3"
REFLECTOR	13' 2"	3' 7"

The Reflector dimensions are only preliminary. Change to get equal side of 9' 6". Fiberglass length is not critical, however, the equal wire length of 9' 6" is very critical.

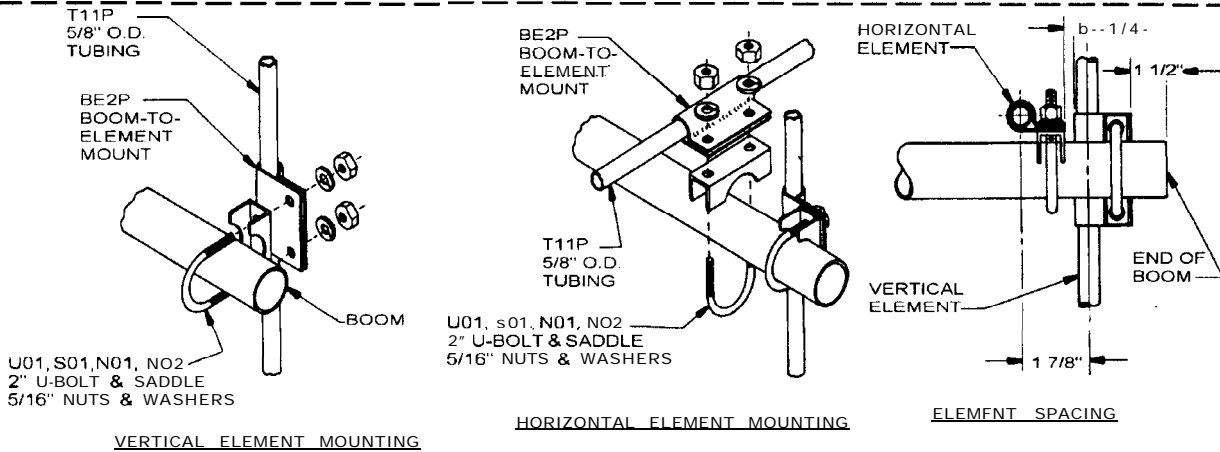
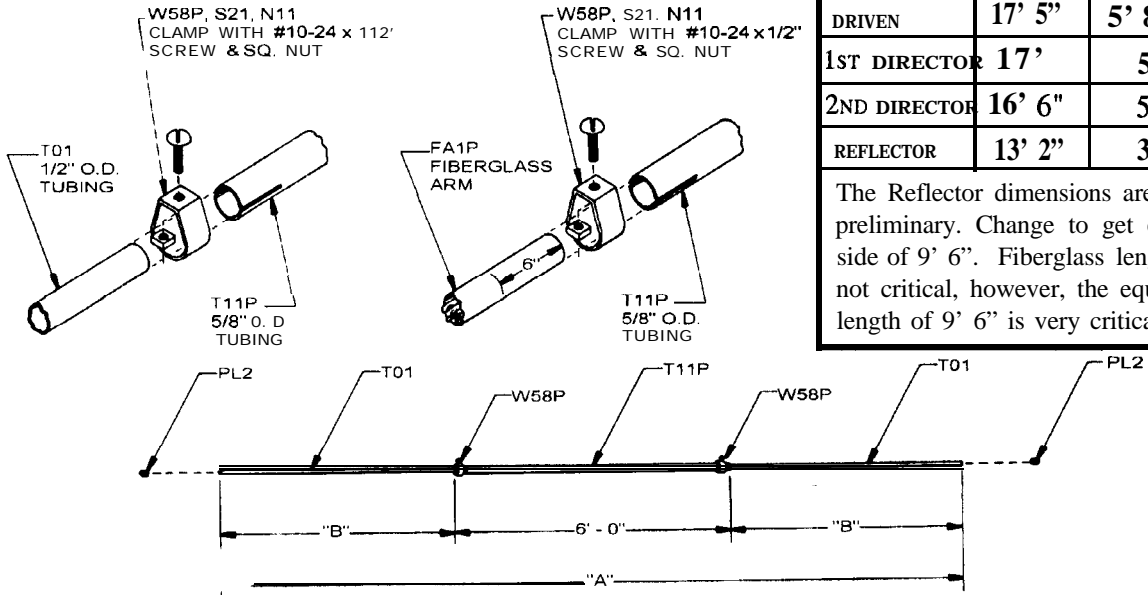

(FIGURE 3B)

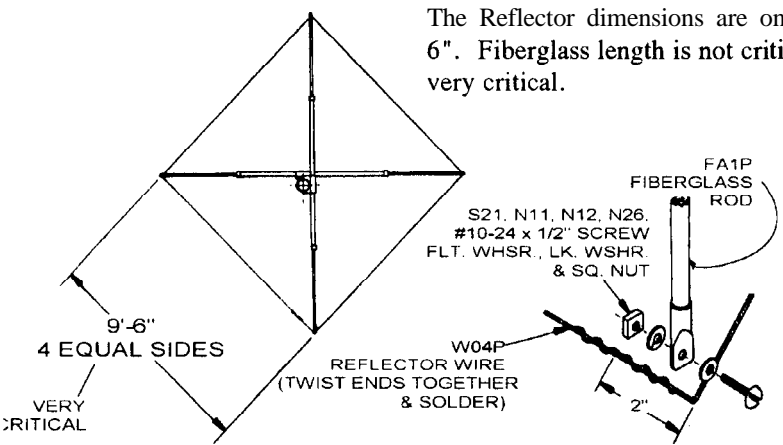

Please read the Assembly and Troubleshooting Tips at the end of this instruction booklet before assembling elements.

SHOOTING STAR

FIGURE 3C

* **NOTE.** THESE DIMENSIONS ARE APPROXIMATE. REFER TO THE INSTRUCTIONS ON ADJUSTING THE S.W.R. TO DETERMINE EXACT SETTINGS. THERE ARE 2 SEPARATE GAMMA ADJUSTMENTS, 1. CAPACITOR ADJUSTMENT, 2. SLIDER POSITION.

DO NOT MOVE BOTH AT THE SAME TIME. MOVE THE CAPACITOR FIRST, THEN, IF NECESSARY MOVE THE SLIDER, AND GO BACK TO THE CAPACITOR.

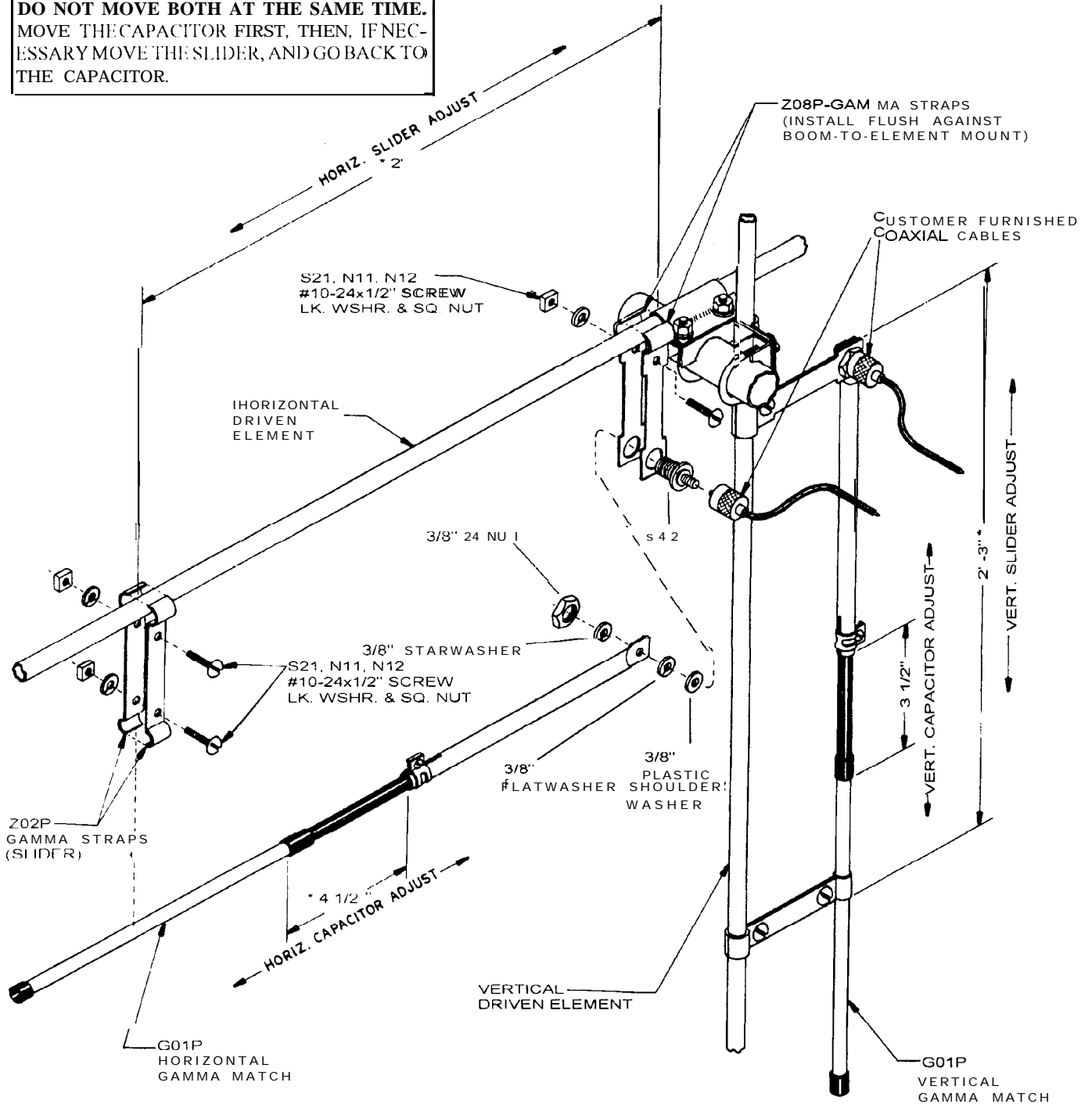

SHOOTING STAR GAMMA MATCH MOUNTING

FIGURE 4